



NSW Submarine Power

Cables for the future, delivered today



NORDDEUTSCHE SEEKABELWERKE GMBH (NSW)

The submarine competence center within the General Cable Group

After NSW was founded in 1899 by Felten & Guilleaume and the Deutsch-Atlantische Telegraphengesellschaft, Siemens became one of its major shareholders in 1931, and acquired the remaining stock in 1995. In 2000, NSW became a subsidiary of Corning Cable Systems. Since 2007, NSW has been a 100-percent member of the General Cable Corporation (NYSE:BGC) and has become the competence center for submarine cables for the General Cable Group.

NSW benefits not only from General Cable's profound expertise but also from its global reach in the wire and cable industry. Quality, state-of-the-art technology and customer focus are General Cable's top priorities.

Experience, Innovation and Service

Norddeutsche Seekabelwerke GmbH (NSW) has been manufacturing underwater cables since

1899. NSW was already laying its first submarine telecommunication cable in 1904, approximately 7,993 kilometers in length.

A century of experience in armored and non-armored submarine cables for carrying power, signals, communications and fiber-optic applications has formed the foundation for a forward-looking organization committed to innovation and unrivalled customer service.

NSW's research-and-development and product-management teams work in close cooperation with General Cable's experts for power transmission as well as leading engineering companies to create state-of-the-art solutions for many of the world's leading power utilities and the oil and gas industry.

Full Service Provider

NSW offers the full range of mechanical, electrical as well

as fiber-optic accessories, e.g. hang-off heads, cable protection systems, power connectors, cable joints, topside cables, fibre-optic splice equipments and any other required cable accessories and supplies.

Taking customer requirements into account, we offer high quality tailor-made solutions or standard products from world-leading manufacturers.

The installation, termination and testing of the cables and their related accessories will be performed by our own highly qualified team of jointers or by well-known specialised companies under supervision of NSW.



SUBMARINE POWER CABLES FOR RENEWABLE ENERGIES

Power transmission and distribution are becoming more and more important to the sustainable energy concept; alternatives to fossil fuels are a necessity for avoiding the disadvantages of CO₂ emissions. Windfarms, tidal power plants and wave-energy converter farms (WEC) are possible answers to this question, which we support proactively with innovative cable concepts.

Offshore Wind Farms

NSW demonstrate extensive experience in delivering and laying cables for the growing offshore wind industry. Together with our customers, we supply individually tailored solutions for power transmission, both for in-field cabling of the wind turbines, and also for connecting windfarms to transformer substations.

NSW  Submarine Power Cables are supplied in all the required lengths. Based on our outstanding history as well as on a wide range of recent projects we are most experienced with all types of turbine and platform connections.

Successful and in-time completion of projects in the North and Baltic Seas have made NSW a valuable partner for national and international power utilities, and for windfarm developers.

Offshore Oil and Gas Industry

Fundamental changes in the exploitation infrastructure in the global oil and gas industry do require state-of-the-art transmission and distribution solutions, based on highly reliable cable designs. As a consequence, tailor-made solutions are needed in most

cases. As recognized experts in submarine power cables for the offshore oil and gas industry, NSW can offer these solutions by meeting the most stringent of industrial requirements. We offer customised, flexible cable solutions, while at the same time being able to access our far-ranging technical knowledge of cable designs. NSW  Submarine Power Cables are reliable and cost-effective even under extreme conditions.

Island Connections

NSW  Submarine Power Cables connect islands to onshore power grids. Helgoland's link to the German power grid with a 53 km MV/AC cable is one of our finest reference projects. Since 2009, this North Sea island, well-known both for its tourism and for its large nature reserve, has no longer needed any diesel generators for producing electricity. The team from NSW has proved that cables can be properly laid even in biosphere reservations in full compliance with the needs of both technology and the natural environment.

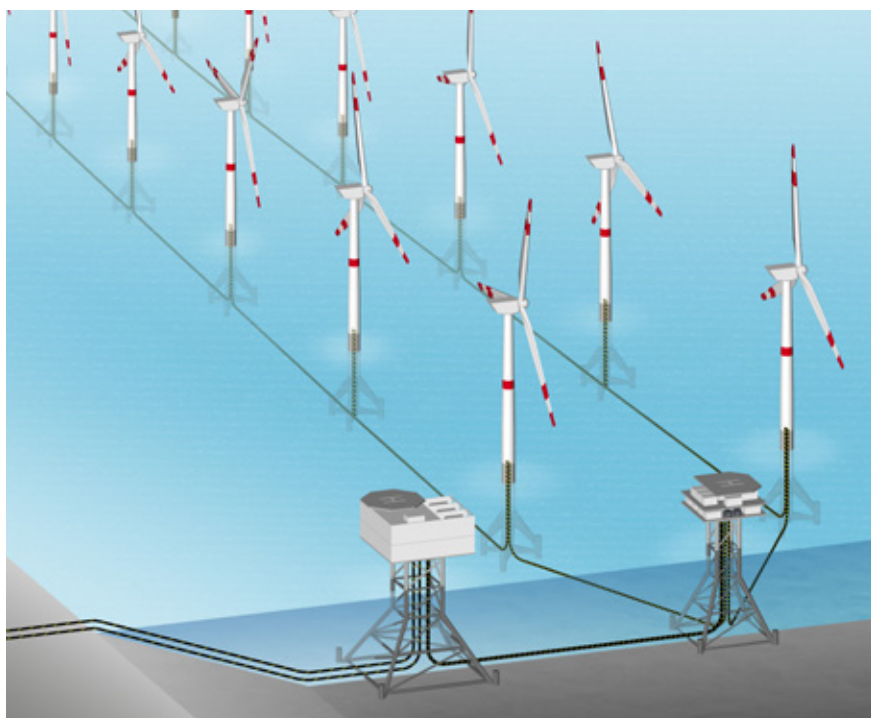

DESIGN OF SUBMARINE POWER CABLES

NSW® Submarine Power Cables are used for various medium and high voltage applications, e.g. in offshore wind farms, the oil & gas industry, island connections, static tidal and wave power applications as well as lake and river crossings.

National and international standards, e.g. IEC, VDE and CIGRE Electra recommendations are respected in NSW's cable design, manufacturing and testing.

NSW offers several cable design options according to individual customer requirements and environmental conditions, e.g. concentric or segmented conductors, XLPE or EPR insulations, tape or wire screens and radial metallic water barriers. The components can also be adapted to peripheral equipment like DTS systems for real-time temperature monitoring.

Tailor-made solutions for specific applications are available. Even complex composite cables with different power and communication elements can be designed and manufactured. HV DC cables as well as inter-array cables operating at increased voltage levels are within the product range of NSW.

High-Voltage AC Submarine Cables up to 270 kV

Example: 3 × 1200 mm² Cu 87/150 kV

- 1 1200 mm² Milliken conductor, water blocked
- 2 Inner semi-conductive layer
- 3 XLPE insulation
- 4 Outer semi-conductive layer
- 5 Swelling tape
- 6 Lead sheath
- 7 Outer sheath semi-conductive PE
- 8 Filler
- 9 Fibre-optic element
- 10 Bedding layer
- 11 Galvanized steel wires filled with bitumen compound
- 12 PP yarn cladding

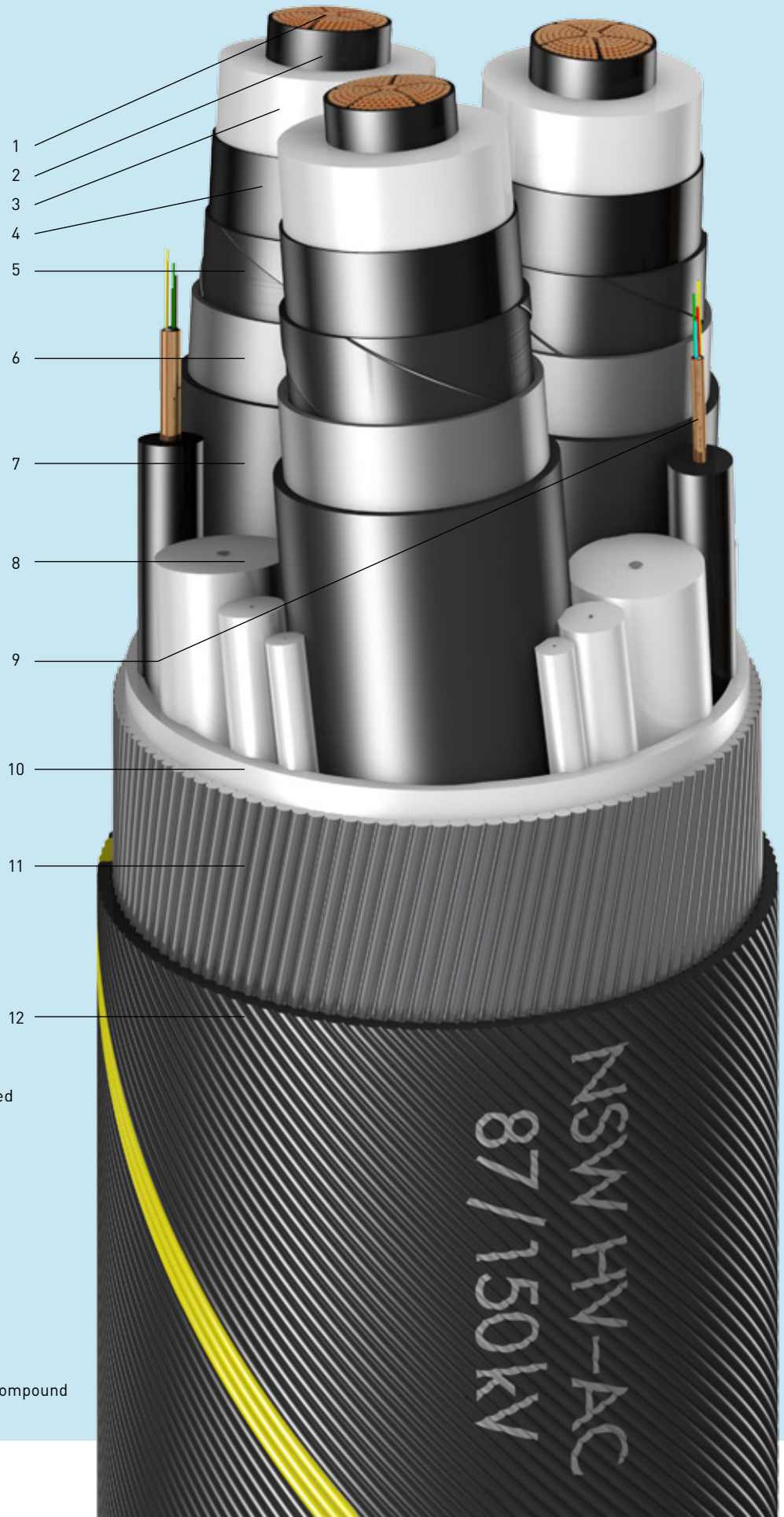

Medium Voltage and Array AC Submarine Cables up to 66 kV

Example: 3 × 120 mm² Cu 18/30 kV

- 1 120 mm² round conductor, water blocked
- 2 Inner semi-conductive layer
- 3 XLPE insulation
- 4 Outer semi-conductive layer
- 5 Swelling tape
- 6 Copper counter helix
- 7 Copper wire screen
- 8 Swelling tape
- 9 Aluminium tape
- 10 Outer sheath
- 11 Filler
- 12 Fibre-optic element
- 13 Bedding layer
- 14 Galvanized steel wires filled with bitumen compound
- 15 PP yarn cladding

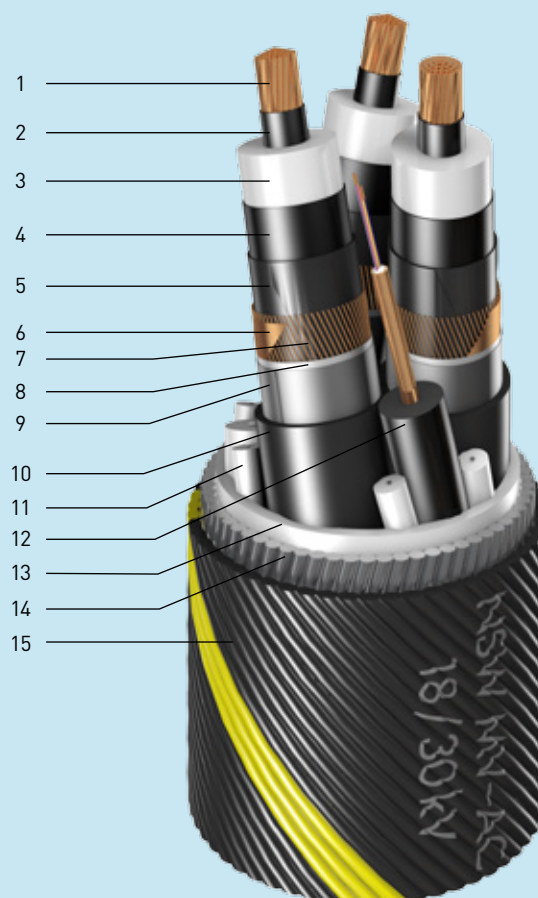

High-Voltage DC Submarine Cables up to 320 kV

Example: 1 × 630 mm² Cu ± 250 kV

- 1 630 mm² round conductor, water blocked
- 2 Inner semi-conductive layer
- 3 XLPE insulation
- 4 Outer semi-conductive layer
- 5 Swelling tape
- 6 Lead sheath
- 7 Outer sheath PE
- 8 Bedding layer
- 9 Galvanized steel wires filled with bitumen compound
- 10 PP yarn cladding

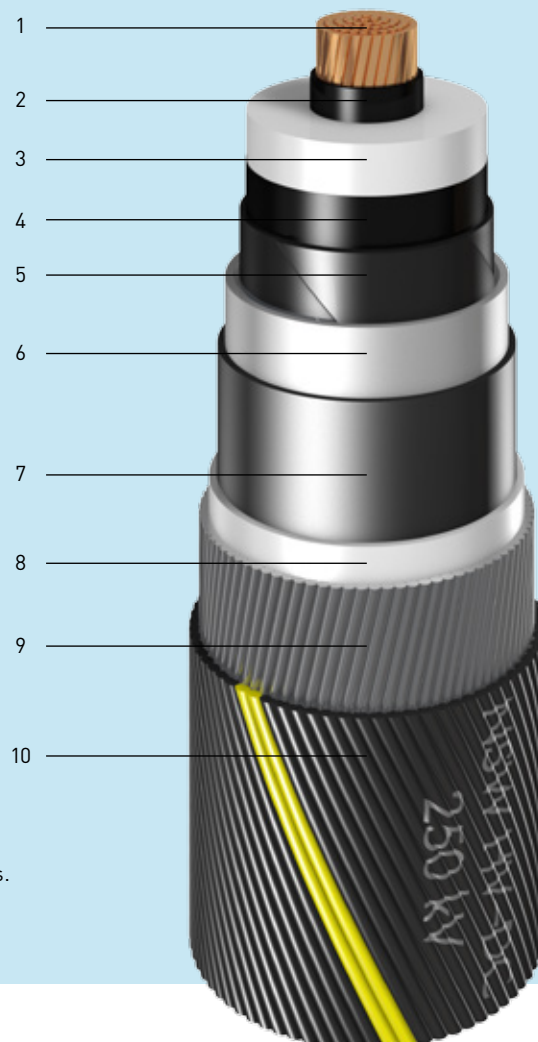

All illustrations are examples for NSW  Submarine Power Cable designs. Please contact NSW for further information.

Illustrations are on a scale of 1:2.26

INSTALLATION OF SUBMARINE POWER CABLES

For over one century, NSW has been acquiring unsurpassed experience and a proven track record in submarine cable installation. Since 2009, NSW has been using this experience also for the installation of submarine power cables, as turn-key solutions with own installation spreads, or with chartered Installation & Trenching Support Vessels.

Project Management and Engineering

NSW's experienced marine engineering team, in close cooperation with our project implementation department, offers full-coverage

complete cable design, engineering and installation capabilities, to meet even the most challenging requirements of interconnection, export and infield sea cable projects. Customers benefit from our long-term project management experience in submarine cable installation for the telecommunication market as well as from a proven track record in turnkey solutions for the offshore wind industry.

Cable Loading at NSW Facilities

NSW's Nordenham facility incorporates its own deep water pier, which is located near the mouth of

the River Weser. Minimum water depth is maintained at 10m, thus providing access to all sizes of cable vessels. The cable load-out system reaching from the factory to the pier is designed to enable continuous lengths of submarine cables to be transferred from the storage areas to the vessel in a two-line parallel loading activity.

Cable Installation

NSW provides specific solutions for a wide variety of cable installation applications as defined by water depth, seabed conditions and deployed offshore structures. Key personnel to supervise

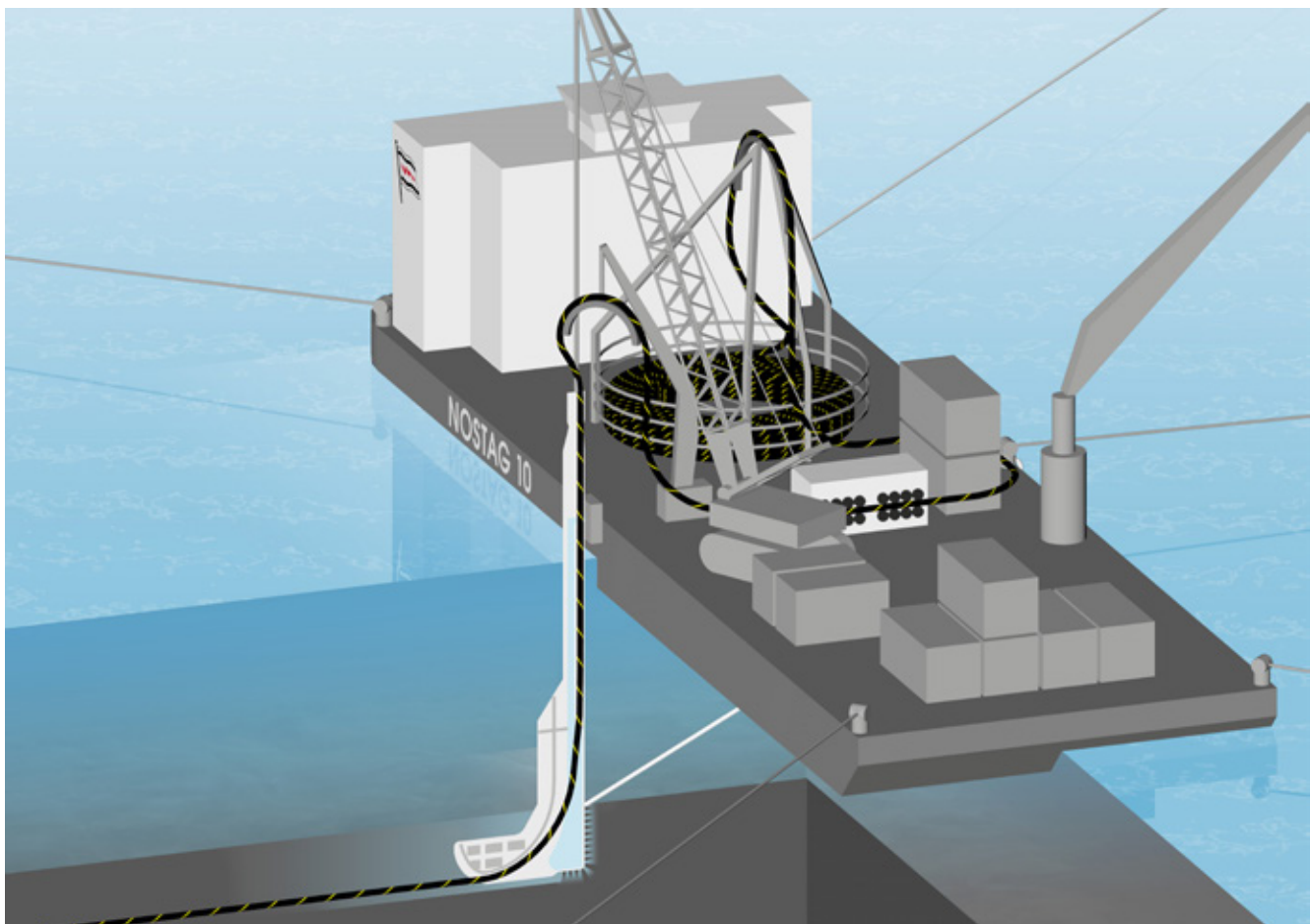

loading, laying and installation procedures are readily available within our regular staff.

NSW is an EC member of the International Cable Protection Committee (ICPC) and all operations, whether cable installation, survey, pre-lay grapnel run/route clearance or post-lay burial are performed in accordance with the applicable ICPC recommendations and local legislative requirements.

NOSTAG 10

NOSTAG 10, the German-flagged, GL approved installation barge, is owned by a consortium of NSW, Hans Schramm & Sohn GmbH & Co. KG and Tiefbau-GmbH "Unterweser" (TAGU). NOSTAG 10 is equipped with five towing winches, anchors, generators, azimuth thrusters, water pumps, linear

cable engines, cranes and sophisticated submarine sensors associated with cable installation.

The barge's flexible cable system has a capacity of up to 3,500 tons of cable. For cable lay and burial a vertical injector is utilized, enabling burial depths up to 7.5 m in one simultaneous operation up to water depths of 35 m. The NOSTAG 10 is beachable, and therefore ideally suited shore-end pull-ins, island connections and other shallow-water applications such as windfarms.

Trencher NSW SeaREX[®]

For other installation services, the cable could be free-laid or buried by means of our ROV trencher NSW[®] SeaREX[®] in a simultaneous lay and burial or in a post-lay burial operation.

Quality Management at NSW

Out of conviction, NSW has implemented quality standards in its company processes and expanded them to an integrated management system according to ISO 9001, ISO TS 29001 and ISO 14001. As work safety is an essential part of NSW's philosophy, we are also certified according to BS OHSAS 18001. Consequently, the synergies created by a holistic system can be employed in the interests of our customers.

Independent companies use regularly occurring inspections to monitor compliance with the requirements of the standards. The certification documents from DNV GL Business Assurance Zertifizierung und Umweltgutachter GmbH attest that NSW uses an active and well-functioning quality and environmental management system.

Measuring and Testing at NSW

A wide range of measuring and test equipment and trained staff experienced in all the relevant measuring methods and test standards is available. NSW works to national and international test standards. In addition, NSW makes use of independent test bodies such as BAM, PTB, VDE, FGH as well as other certified laboratories.

In order to assure the quality of NSW products, intensive, long-term investigations are carried out on the product and materials, going far beyond the specified test requirements. The continuous checking, monitoring and evaluation of the tests is just as much a part of the investigations as the subsequent documentation of the results.





GERMANY
Tel: +49 4731 82 13 30
power@nsw.com

NORWAY
Tel: +47 649 559 00
firmapost@generalcable.no

UNITED KINGDOM
Tel: +44 (0) 132 549 53 70
info@generalcable.co.uk



© March 2016 General Cable. All rights reserved.